

Asymmetric Synthesis of γ,γ -Dialkyl- γ -aminobutyric Acid Analogues and 2,2-Disubstituted Pyrrolidines. Control of Stereochemistry in Amino Ring Opening by Varying the Extent of Allylic 1,3-Strain

Laurence E. Burgess and A. I. Meyers*

Department of Chemistry, Colorado State University
Fort Collins, Colorado 80523

Received August 5, 1991

γ -Aminobutyric acid (GABA) (1) is a nonprotogenic amino acid which functions as an important inhibitory neurotransmitter in the mammalian brain.¹ This simple substance mediates more than 40% of all inhibitory synaptic activity, and several GABA analogues have been implicated as important therapeutics in the treatment of neurological and psychiatric disorders.² We describe our preliminary results concerning a facile route to the preparation of GABA analogues 2 and 2,2-disubstituted pyrrolidines 3, both containing an asymmetric quaternary carbon center. Furthermore, a study to assess the key allylation reaction provided means for either enhancement or complete reversal of the diastereoselection through variation of the chiral auxiliary.

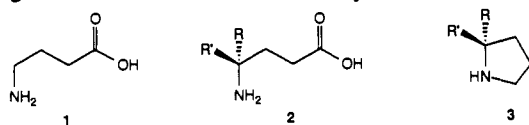

Scheme I portrays the synthetic approach originating from the readily prepared chiral bicyclic lactams 4,³ which were exposed to allyltrimethylsilane and titanium(IV) tetrachloride, furnishing allylated pyrrolidinones 5 in excellent yields. The diastereoselection in 5 ranged from 5:1 for the angular methyl bicyclic lactam (4, R = Me) to 2:1 for the angular isopropyl bicyclic lactam (4, R = *i*-Pr).⁴ However, the excellent yield of the reaction allowed isolation (radial chromatography with mixtures of ethyl acetate/hexanes) of the major diastereomers, 5a-c, in good yields (60-80%). Moreover, changes in the chiral amino alcohol led to drastic changes in stereoselectivity (*vide infra*). The absolute stereochemistry of 5b, the major diastereomer,⁵ was determined by an X-ray crystallographic study.⁶

Reductive cleavage of the phenylglycinol moiety in 5, under dissolving metal conditions, provided the versatile pyrrolidinones 6a-c in good yield and allowed access to both the GABA analogues and 2,2-disubstituted pyrrolidines. Thus, acylation of 6a-c with the carbobenzyloxy group followed by methanolysis furnished the acyclic N-protected γ -amino esters 7a-c, whereas hydride reduction of 6 gave the pyrrolidines 8a-c. Yields for both series were quite satisfactory.⁷

(1) (a) Roberts, E.; Chase, T. N.; Tower, D. B. *GABA in Nervous System Function*; Raven Press: New York, 1976. (b) Sytinsky, I. A.; Sodatenkov, A. T.; Lajtha, A. *Prog. Neurobiol.* **1978**, *10*, 89. (c) Rando, R. R. *Acc. Chem. Res.* **1975**, *8*, 281. (d) Squires, R. F. *GABA and Benzodiazepine Receptors*; CRC Press: Boca Raton, 1988; Vols. 1 and 2. (e) Bowery, N. G.; Bittiger, H.; Olpe, H.-R. *GABA_B Receptors in Mammalian Function*; John Wiley & Sons: New York, 1990.

(2) (a) Krogsgaard-Larsen, P. In *Amino Acids as Chemical Transmitters*; Fonnum, F., Ed.; Plenum: New York, 1978; p 305. (b) Krogsgaard-Larsen, P.; Scheel-Kruger, J.; Kofod, H. *GABA-Neurotransmitters: Pharmacological, Biochemical and Pharmacological Aspects*; Munksgaard: Copenhagen, 1979. (c) Rando, R. R.; Bangert, F. W. *J. Am. Chem. Soc.* **1977**, *99*, 5141. (d) Rando, R. R.; Bangert, F. W. *J. Am. Chem. Soc.* **1976**, *98*, 6762. (e) Jung, M. J.; Metcalf, B. W. *Biochem. Biophys. Res. Commun.* **1975**, *67*, 301. (f) Papaioannou, D.; Stavropoulos, G.; Silvas, M.; Barlos, K.; Francis, G. W.; Aksnes, D. W.; Maartmann-Moe, K. *Acta Chem. Scand.* **1991**, *45*, 99.

(3) Meyers, A. I.; Burgess, L. E. *J. Org. Chem.* **1991**, *56*, 2294 and references cited therein.

(4) Ratios were determined by 300-MHz ¹H NMR spectroscopy. For R = H, a 10:1 ratio was obtained (see ref 3). For complete data and experimental details, see the supplementary material.

(5) The ¹H NMR signal for the internal olefinic proton in 5 was distinctive (chemical shift) for each diastereomer: for R = methyl, major (δ 5.42) and minor (δ 5.80); for R = butyl, major (δ 5.36) and minor (δ 5.83); for R = isopropyl, major (δ 5.14) and minor (δ 5.86).

(6) Performed by S. Miller and O. P. Andersen and submitted to *Acta Crystallogr.* for publication.

Table I

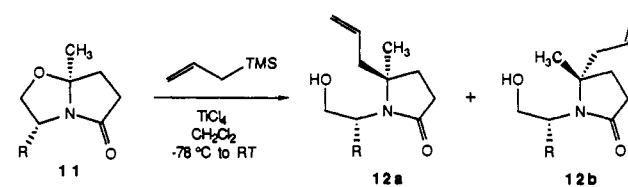

R	diastereomeric ratio 12a:12b
methyl	8:1
phenyl	5:1
isopropyl	1:2
<i>tert</i> -butyl	1:11

Further synthetic utility of the enantiomerically pure allyl-substituted pyrrolidinone 6a was demonstrated by conversion to the azabicyclo[3.3.0]octane 9 via exposure to selenium-mediated cyclization conditions.⁸ This bicyclic system contains the skeletal array of the important pyrrolidine alkaloids.

The stereochemistry observed for the disubstituted lactam 5 was in contrast to our earlier reports on the cleavage of these acetal centers. Previously, allylation of the angular hydrogen lactam (4, R = H) gave the product with inversion at the angular position (10). These results were consistent with previous studies⁹ on the

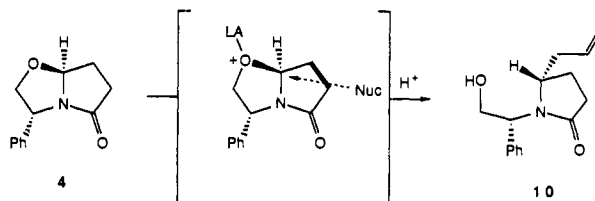

cleavage of acetals under Lewis acid conditions wherein the ring oxygen bond is partially broken due to complexation, thus allowing an S_N2-like delivery of the nucleophile from the α -face. In the present study the allyl group entered the congested β -face, furnishing the product with retained configuration (4 to 5, Scheme I).

In an effort to understand this anomalous stereochemical outcome, the steric bulk of the auxiliary was varied (Table I). Thus, replacing the phenylglycinol auxiliary in 4 with that derived from alanine (11, R = Me), valine (11, R = *i*-Pr), or *tert*-leucine (11, R = *t*-Bu) gave widely varying ratios of the 5-allylpyrrolidinones 12a (retention) and 12b (inversion).¹⁰ The selectivity observed for allylation ranged from 8:1 for methyl to a complete reversal of 1:11 for the *tert*-butyl group, results which significantly improve the synthetic value. A mechanistic picture emerges that involves a combination of the Felkin-Ahn model for nucleophilic addition, allylic 1,3-strain, and chelation effects.

If one considers the initially formed *N*-acyliminium ion A (Scheme II, looking down the C-N bond), in which R is the alkyl group derived from the various amino alcohol auxiliaries, then according to allylic 1,3-strain,¹¹ a 120° rotation to B or a 180° rotation to C should minimize this strain by directing the small hydrogen atom toward the congested olefinic center. From the model of Felkin and Ahn,¹² when R is a large group (*i.e.*, *tert*-butyl

(7) Due to the volatility of the pyrrolidines 8, they were isolated as hydrochlorides and characterized as the trifluoromethanesulfonamides. Physical constants and experimental details are given in the supplementary material.

(8) Tiecco, M.; Testaferri, L.; Tingoli, M.; Bartoli, D.; Balducci, R. *J. Org. Chem.* **1990**, *55*, 429.

(9) (a) Ishihara, K.; Mori, A.; Yamamoto, H. *Tetrahedron* **1990**, *46*, 4595. (b) Mori, I.; Flippin, L. A.; Nozaki, K.; Yamamoto, H.; Bartlett, P. A.; Heathcock, C. H. *J. Org. Chem.* **1990**, *55*, 6107. (c) Alexakis, A.; Mangeney, P. *Tetrahedron: Asymmetry* **1990**, *1*, 477.

(10) The configurations of products 12a and 12b were assigned by correlation with pyrrolidinone 6a ([α]_D = +16°). Thus cleavage of the auxiliary in 12a via the phenyl sulfide derivative (see ref 3) provided 6a. Comparison of optical rotation confirmed enantiomeric identity.

(11) Hoffmann, R. W. *Chem. Rev.* **1989**, *89*, 1841-1860 and references therein.

Scheme I

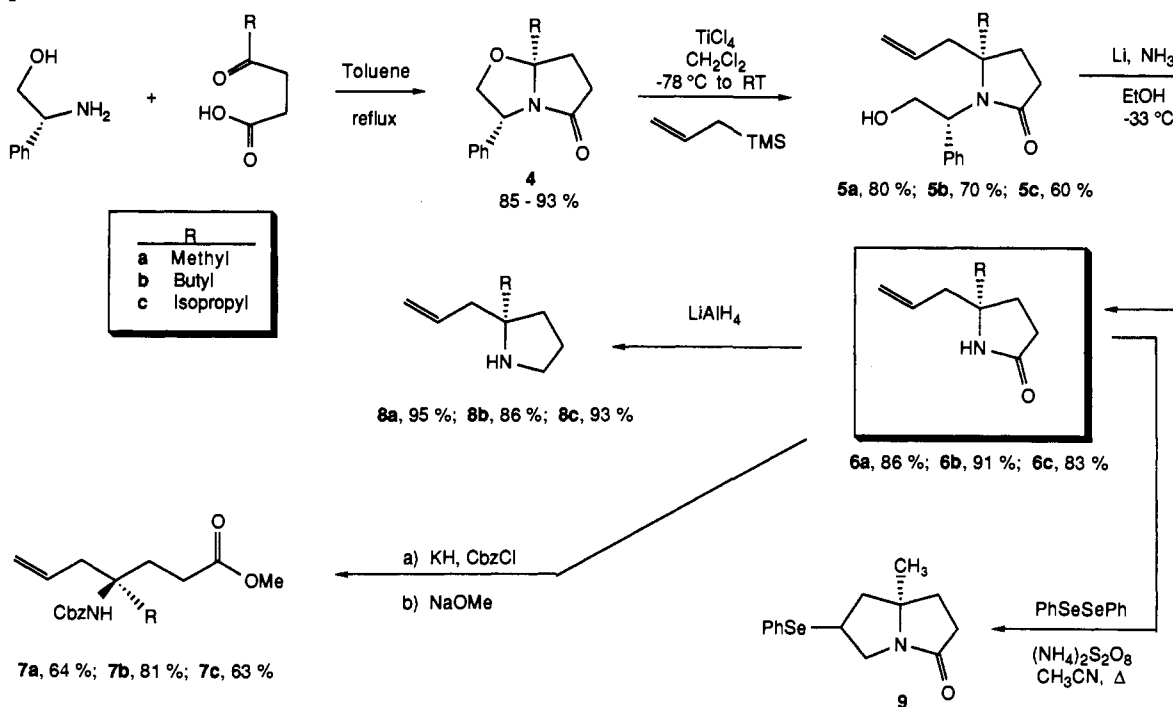

Scheme II

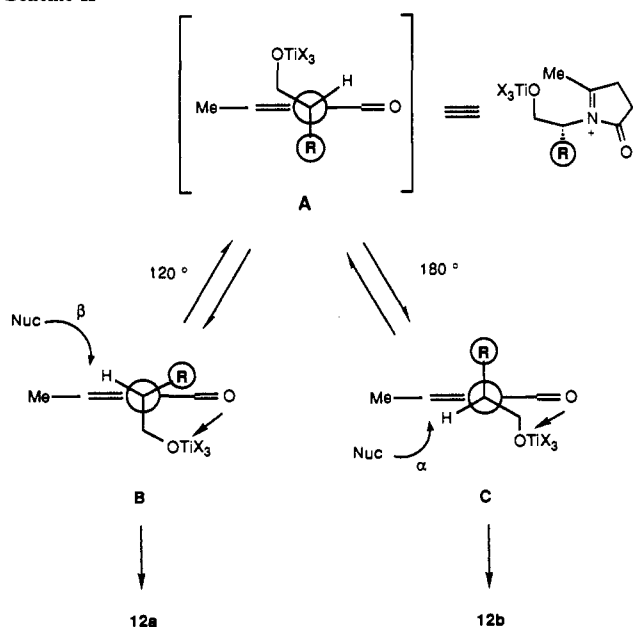

and isopropyl), entry by silane occurs from the face opposite this large group (C) to generate the product (α -entry) of inversion (**12b**). Alternatively, when R is the smaller group (methyl or phenyl), the alkoxytitanium assumes the role of the large group and occupies the antiperiplanar position (B), thus directing the entry from the β -face to provide **12a**. The acyliminium ion derived from the phenylglycinol moiety may also involve several stereoelectronic factors.¹³ Finally, and perhaps of equal significance, there exists the possibility of a seven-membered-ring chelate in B and C derived from the alkoxytitanium and the carbonyl oxygen.

The present study provides a remarkable example of how the stereochemistry of Lewis acid-allylsilane alkylations may be altered (inversion or retention at the electrophilic carbon) by simply changing the nature of the auxiliary group from small (methyl)

to large (*tert*-butyl), rather than altering the stereocenter. Additionally, the stereoselectivity leading to **12a** or **12b** is found to increase significantly (5:1 versus 8:1 in phenyl to methyl and 1:2 versus 1:1 in isopropyl to *tert*-butyl), suggesting a protocol to reach maximum selectivity. Further studies are in progress to fully evaluate the potential of this system.

Acknowledgment. Support for this research by grants from the National Institutes of Health is gratefully acknowledged.

Supplementary Material Available: Complete experimental details for the preparation of compounds **4a-c** through **8a-c** and **9**, including all physical data (14 pages). Ordering information is given on any current masthead page.

Amphidinol, a Polyhydroxypolyene Antifungal Agent with an Unprecedented Structure, from a Marine Dinoflagellate, *Amphidinium klebsii*

Masayuki Satake, Michio Murata, and Takeshi Yasumoto*

Faculty of Agriculture, Tohoku University
Sendai 981, Japan

Tsuyoshi Fujita and Hideo Naoki*

Suntory Institute for Biorganic Research
Mishima-gun, Osaka 618, Japan

Received September 5, 1991

Marine dinoflagellates are attracting much attention as a rich source of bioactive compounds, e.g. brevetoxins, ciguateroxins, maitotoxin, and okadaic acid.¹ While screening dinoflagellate cultures for bioactive compounds, we discovered a potent antifungal agent, amphidinol (**1**) in cultures of the dinoflagellate *Amphidinium klebsii*. In this communication we report the structural elucidation of amphidinol, which is the first member

(12) Ahn, N. T. *Top. Curr. Chem.* **1980**, *88*, 145.

(13) Polniaszek, R. P.; Belmont, S. E.; Alvarez, R. J. *Org. Chem.* **1990**, *55*, 215.

(1) (a) Lin, Y.-Y.; Risk, M.; Ray, S. M.; Engen, D. V.; Clardy, J.; Golik, J.; James, J. C.; Nakanishi, K. *J. Am. Chem. Soc.* **1981**, *103*, 6773-6775. (b) Murata, M.; Legrand, A. M.; Ishibashi, Y.; Fukui, M.; Yasumoto, T. *J. Am. Chem. Soc.* **1990**, *112*, 4381-4386. (c) Murakami, Y.; Oshima, Y.; Yasumoto, T. *Bull. Jpn. Soc. Sci. Fish.* **1982**, *48*, 69-72.